

# Homey

7 COLOURS

4 SIZES

1 SURFACE

Today more than ever we perceive how important it is to have a comfortable and cozy home. Our safe place where to find peace, tranquility and love. The Homey collection is ideal to create a homey house through its warm materiality.

Mai come in questo momento percepiamo quanto sia importante avere una casa confortevole e accogliente. Il nostro luogo sicuro dove trovare pace, tranquillità e amore. La collezione Homey è ideale per creare attraverso la sua calda matericità una casa gradevole e ospitale.

Niemals mehr als in diesem Moment sind wir uns bewusst, wie wichtig es ist, ein komfortables und einladendes Zuhause zu haben. Unser sicherer Ort, um Frieden, Ruhe und Liebe zu finden. Die Homey-Kollektion ist durch ihre warme Materialität ideal, um ein angenehmes und gemütliches Zuhause zu schaffen.

Jamais comme en ce moment nous ne percevons combien il est important d'avoir une maison confortable et accueillante. Notre endroit sûr pour trouver la paix, la tranquillité et l'amour. La collection Homey est idéale pour créer une maison agréable grâce à sa matérialité chaude.

## Homey



Spazi Residenziali  
Residential Spaces

P. 4

Informazioni Tecniche  
Technical Information

P. 30

Tecnologia e Superfici  
Technology & Surfaces

P. 32



s

La serie Homey è ispirata all'idea di ottenere superfici dall'aspetto naturale prendendo spunto dalla terra, nello specifico l'argilla con i suoi colori caldi e le sfumature 'ton sur ton' ottenendo una superficie morbida, ideale per una casa calda e confortevole.

Dall'argilla, pressata in forme stabilite, asciugata e cotta vengono creati i laterizi di vari ornamenti architettonici utilizzati in edilizia.

La collezione Homey trae ispirazione da queste forme di laterizio e propone una struttura a mattoncini sia in versione naturale che smaltata lucida.

Si inserisce in questa collezione la nuova struttura Homey Cannelé il cui effetto tridimensionale vivacizza gli ambienti e dona alle pareti un tocco di originalità.



The Homey series is inspired by the idea of obtaining natural-looking surfaces inspired by the earth, specifically clay with its warm colors and shades 'ton sur ton' obtaining a soft surface, ideal for a warm and cozy home. From the clay, pressed in established forms, then dried and fired, are created the bricks of various architectural ornaments used in construction.

The Homey collection draws inspiration from these brick shapes and presents a structure in both natural and glossy finish.

Die Homey-Serie ist von der Idee inspiriert, natürlich aussehende Oberflächen zu erhalten, die sich von der Erde inspirieren lassen, insbesondere die Tonerde mit seinen warmen Farb- auf Farbtönen, um eine sanfte Oberfläche zu erhalten, die ideal für ein warmes und komfortables Zuhause ist.

Aus dem fest gepressten Ton, der anschliessend getrocknet und gebrannt wird, entstehen die Ziegelsteine verschiedener architektonischer Ornamente, die im Bauwesen verwendet werden.

Die Homey-Kollektion ist von diesen Ziegelformen inspiriert und bietet eine Ziegelstruktur sowohl in natürlicher als auch in glänzend glasierter Ausführung.

La série Homey est inspirée par l'idée d'obtenir des surfaces à l'aspect naturel en s'inspirant de la terre, en particulier l'argile avec ses couleurs chaudes et les nuances 'ton sur ton' en obtenant une surface douce, idéale pour une maison chaude et confortable.

À partir de l'argile pressée dans des formes établies, séchée et cuite, des briques de divers ornements architecturaux utilisés dans la construction sont créées.

La collection Homey s'inspire de ces formes de briques et propose une structure en briques aussi bien en version naturelle qu'en émail brillant.

# Spazi Residenziali

Residential Spaces  
Wohnanlagen  
Espaces Résidentiels

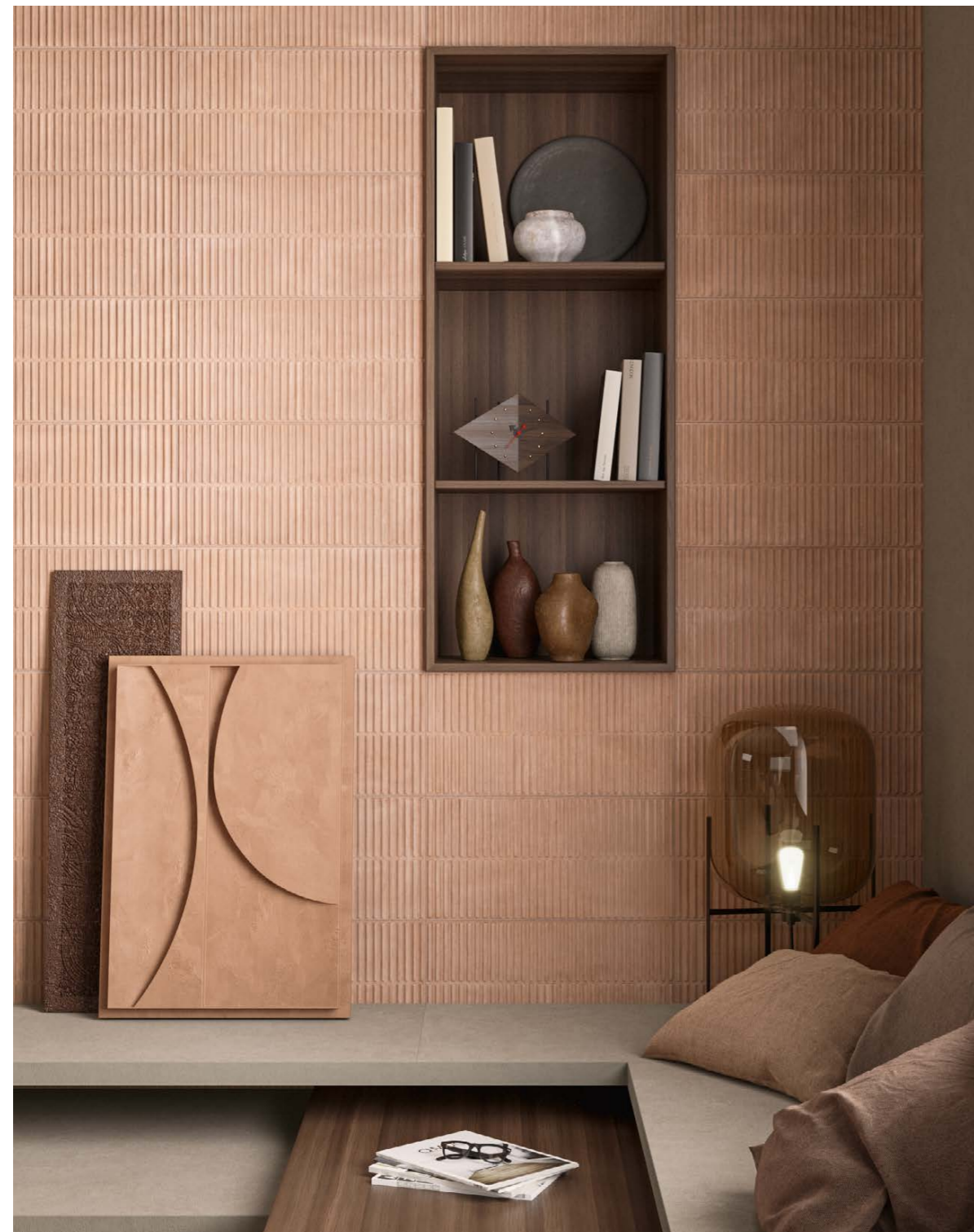

COLORI / COLOURS

AMBIENTI / AMBIENT

PAGINA / PAGE

|  |               |    |
|--|---------------|----|
| Cotto / Taupe / Stripes Powder Mat       | Living        | 6  |
| Taupe / Cotto / Stripes White - Clay Mat | Dining        | 8  |
| Chalk / Berry / Stripes Grey Mat         | Kitchen       | 12 |
| Flower Chalk / Stripes White Glossy      | Pantry        | 14 |
| Bloom Blue / Cloudy / Chalk              | Bathroom      | 16 |
| Bloom White / Rammed Warm                | Wellness area | 18 |
| Chalk / Sage / Stripes White Mat         | Bedroom       | 20 |
| Cloudy / Dove                            | Bathroom      | 24 |
| Rammed Cold / Taupe                      | Studio        | 28 |



Taupe / Cotto / Stripes White - Clay Mat

30x60 - 12"x24" Stripes White Mat Rettificato  
30x60 - 12"x24" Stripes Clay Mat Rettificato



60x120 - 24"x48" Taupe Naturale Rettificato

60x120 - 24"x48" Cotto Naturale Rettificato



## Flower Cotto

Free interpretations of original and dynamic flooring surfaces that furnish every space. The ideal floral pattern for homey and contemporary environments.

Freie Interpretationen origineller und dynamischer Bodenbeläge, die jeden Raum einrichten. Das ideale Blumenmotiv für warme, komfortable und moderne Umgebungen.

Interprétations libres des surfaces pour les sols originaux et dynamiques qui meublent chaque espace. Le motif floral idéal pour les environnements chauds, confortables et contemporains.

Libere interpretazioni di superfici per pavimentazioni originali e dinamiche che arredano ogni spazio. Il motivo floreale è ideale per ambienti caldi, confortevoli e contemporanei.

60×120 - 24"×48" Flower Cotto Naturale Rettificato



Honey  
Residential Spaces

Chalk / Berry / Stripes Grey Mat



60x120 - 24"x48" Berry Naturale Rettificato  
30x60 - 12"x24" Stripes Grey Mat Rettificato

60x120 - 24"x48" Flower Chalk Naturale Rettificato  
60x60- 24"x24" Chalk Naturale Rettificato





# Flower Chalk

60x120 - 24"x48" Flower Chalk Naturale Rettificato



# Berry / Stripes White Glossy

60x120 - 24"x48" Berry Naturale Rettificato  
30x60 - 12"x24" Stripes White Glossy Rettificato

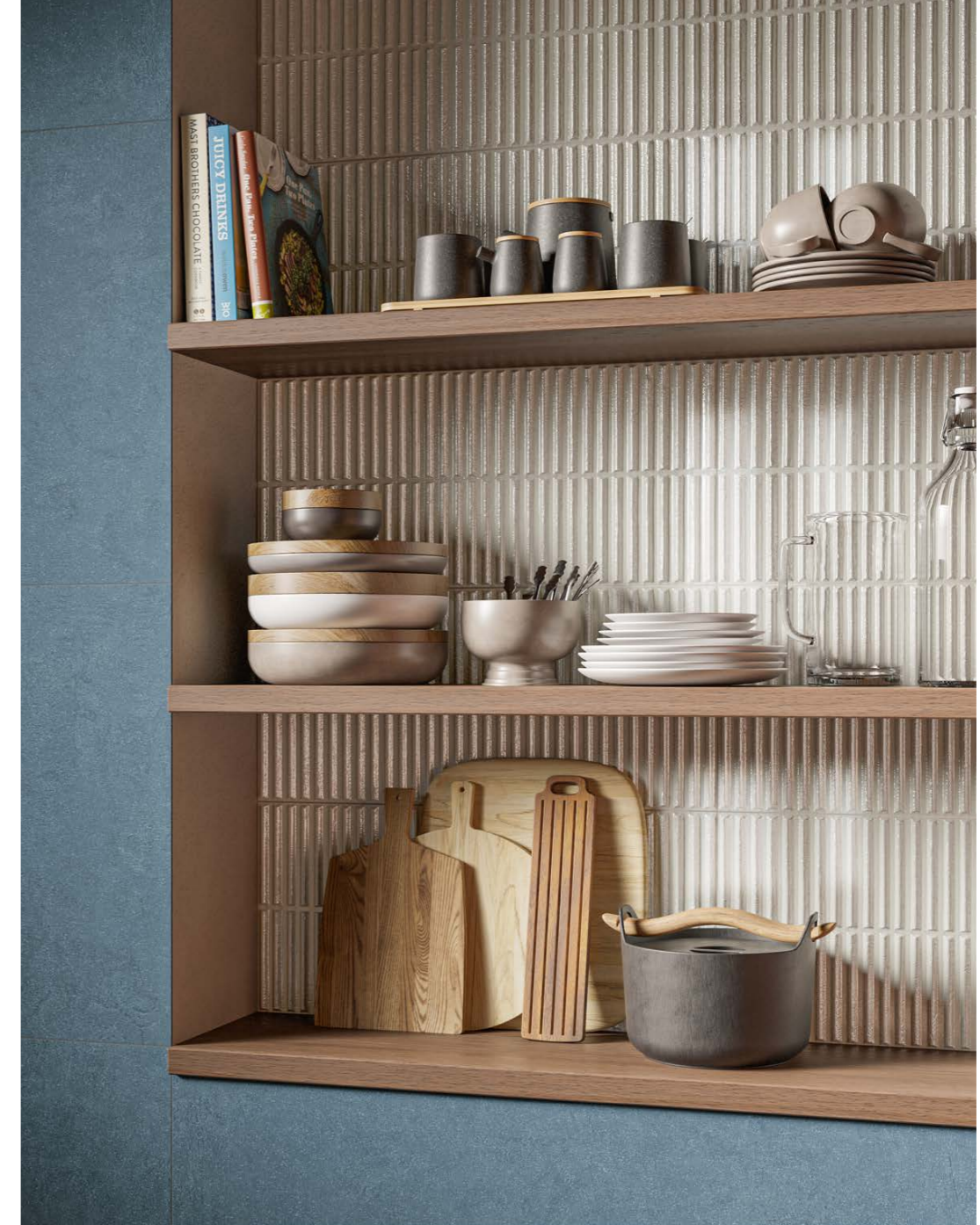



60x120 - 24"x48" Chalk Naturale Rettificato  
120x120 - 48"x48" Cloudy Naturale Rettificato

60x120 - 24"x48" Bloom Blue Naturale Rettificato



Bloom White / Chalk / Cotto

60x120 - 24"x48" Bloom White Naturale Rettificato  
60x120 - 24"x48" Chalk, Cotto Naturali Rettificati



Rammed Warm / Taupe

60x120 - 24"x48" Rammed Warm Naturale Rettificato  
120x120 - 48"x48" Taupe Naturale Rettificato









Dove / Stripes Mustard Glossy  
Cloudy / Stripes Blue Glossy

30x60 - 12"x24" Stripes Mustard Glossy Rettificato  
120x120 - 48"x48" / 60x120 - 24"x48" Dove Naturale Rettificato



30x60 - 12"x24" Stripes Blue Glossy Rettificato

120x120 - 48"x48" Cloudy Naturale Rettificato



## Rammed Cold / Taupe

Sizes and decorations alternate and are mixed in a balanced way creating cozy environments.

Größen und Dekorationen wechseln sich ab und werden auf ausgewogene Weise kombiniert, um einladende Umgebungen zu schaffen.

Les formats et les décorations alternent et s'harmonisent de manière équilibrée pour créer des environnements accueillants.

Formati e decorazioni si alternano e si accostano in modo equilibrato creando ambienti accoglienti.

60×120 - 24"×48" Rammed Cold Naturale Rettificato

120×120 - 48"×48" Taupe Naturale Rettificato





# Informazioni Tecniche

7

Colori  
Colours  
Farben  
Couleurs



4

Formati  
Sizes  
Formate  
Formats

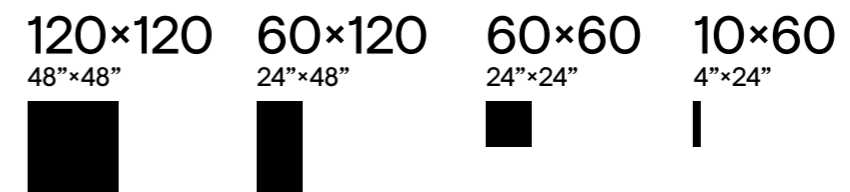

1

Superfici  
Surfaces  
Oberflächen  
Surfaces

Naturale

2

Strutture 3D  
3D structures  
Strukturen  
Décorations en relief

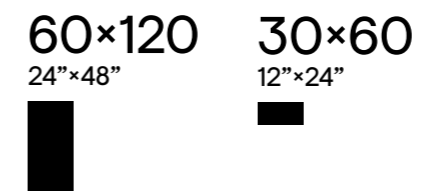

8

Colori  
Colours  
Farben  
Couleurs



6

Colori  
Colours  
Farben  
Couleurs

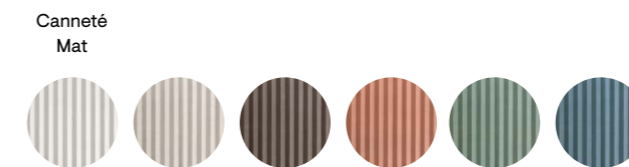

i

Effetto Contemporaneo  
Contemporary effect  
Modern Wirkung  
Effet Contemporain

Rivestimento  
Wall Tiles  
Wandfliesen  
Revêtement

Pavimento  
Floor Tiles  
Bodenfliesen  
Sol

Gres fine porcellanato ad impasto colorato  
Coloured-body fine porcelain stoneware  
Feinsteinzeug aus farbiger Masse  
Grès cérame fin à pâte colorée

Tecnologia digitale  
Digital technology  
Digital technologie  
Technologie numérique

## Superficie Naturale / Natural Surface

Homey has a slightly wavy and opaque texture, capable of creating surfaces that evoke the warm materiality of clay. A contemporary material with the resistance qualities of porcelain stoneware.

Homey hat eine leicht bewegte und matte Textur, die in der Lage ist, Oberflächen zu erzeugen, die an die warme Textur von Tonerde erinnern. Ein zeitgemäßes Material mit den Festigkeitseigenschaften von Feinsteinzeug.

Homey a une texture légèrement ondulée et mate, capable de créer des surfaces qui évoquent la matière chaude de l'argile. Une matière contemporaine avec de qualités de résistance propres au grès cérame.

Homey ha una texture lievemente mossata e opaca, capace di creare superfici che evocano la calda matericità dell'argilla. Una materia contemporanea con le qualità di resistenza proprie del gres porcellanato.

60x120 - 24"x48" Cotto Naturale Rettificato

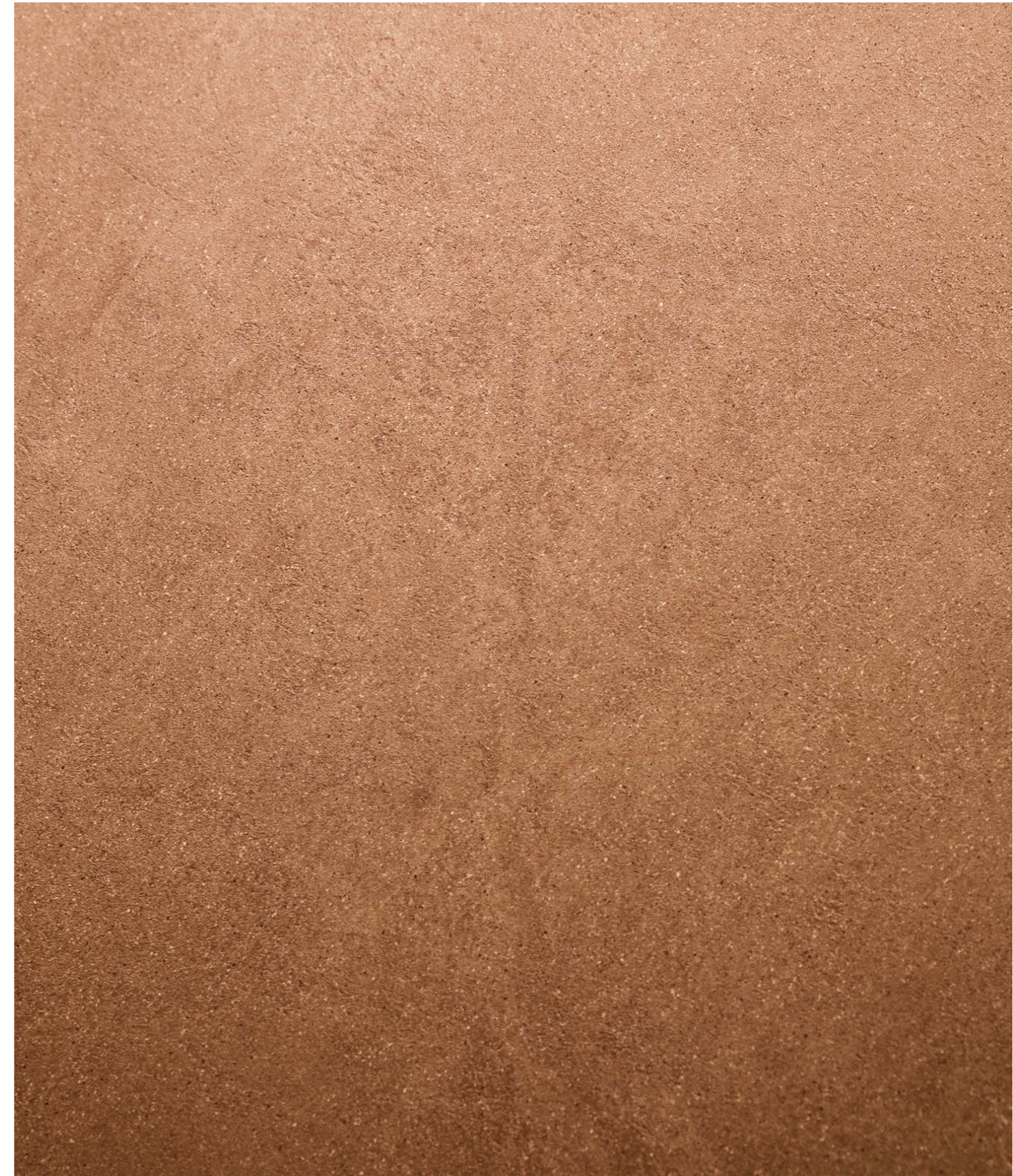

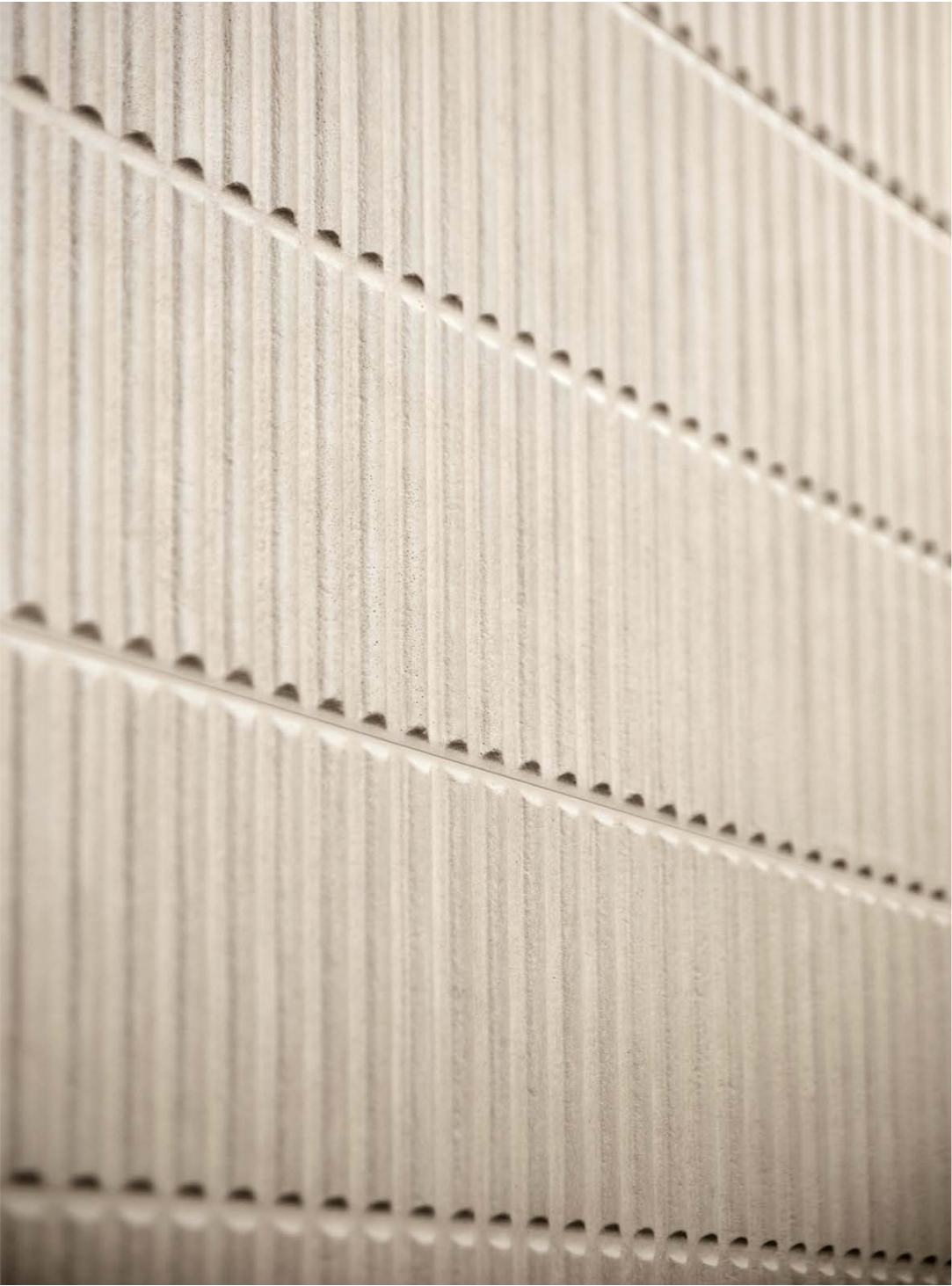

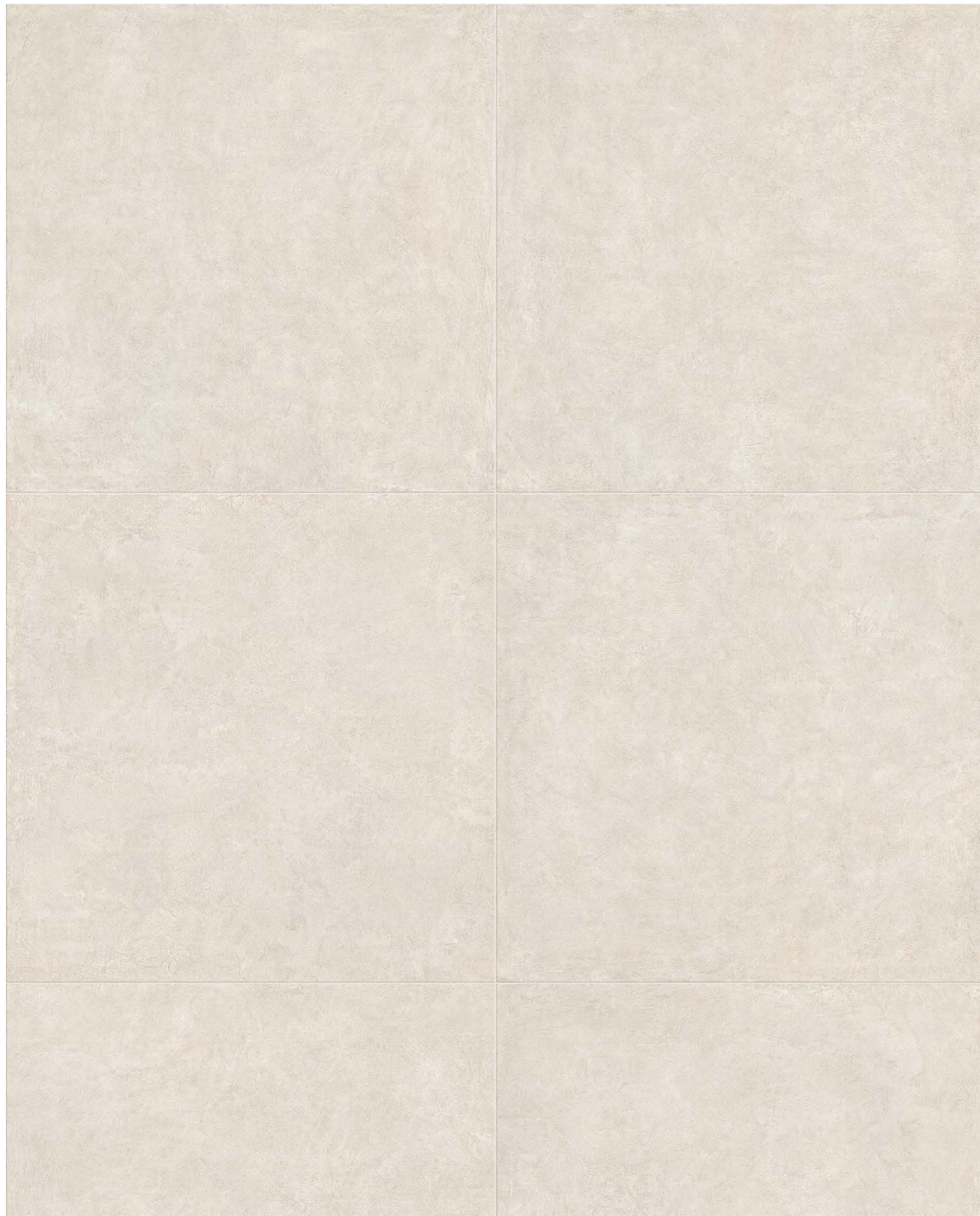

Gres fine porcellanato ad impasto colorato  
Tecnologia Digitale

Coloured-body fine porcelain stoneware  
Digital Technology

Feinsteinzeug aus farbiger Masse  
Digital Technologie

Grès cérame fin à pâte colorée  
Technologie Numérique

# Chalk

Per un risultato di posa ottimale si consiglia di prelevare le piastrelle da 5/6 scatole contemporaneamente.

For best installation results, we suggest taking the tiles from 5/6 boxes at the same time.

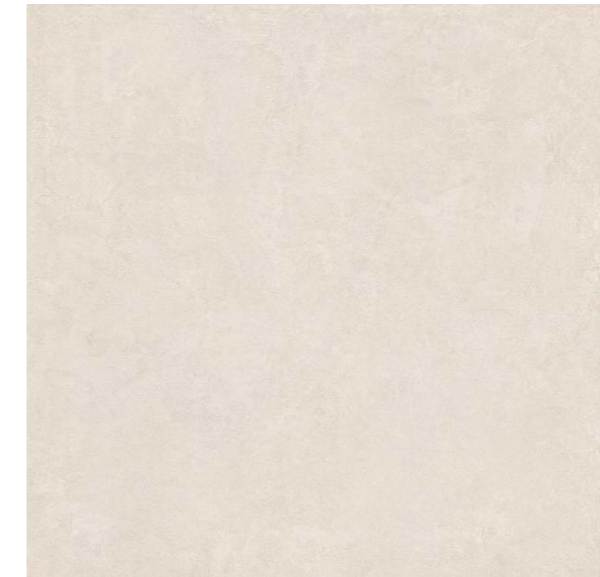

± 9

120×120 - 48"×48"

**05245** | Homey Chalk Nat/Ret



± 9,5

60×120 - 24"×48"

**05216** | Homey Chalk Nat/Ret

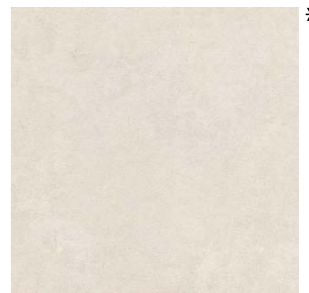

± 9,5

60×60 - 24"×24"

**05224** | Homey Chalk Nat/Ret



60×120 - 24"×48"

\* **05243** | Homey Rammed Cold Nat/Ret  
(mix 9 graphics)



60×120 - 24"×48"

**05276** | Homey Bloom White Nat/Ret  
(mix 6 graphics)



± 9,5

10×60 - 4"×24"

**05277** | Homey Chalk Nat/Ret



60×120 - 24"×48"

\* **05244** | Homey Rammed Warm Nat/Ret  
(mix 9 graphics)

\* Per la continuità di posa, si consiglia il verso della grafica come da minimale a catalogo  
For continuity of installation, we recommend the direction of the graphics as per picture in the catalogue  
Für eine kontinuierliche Verlegelinie empfehlen wir die Verlegung gemäß der Abbildung im Katalog  
Pour la continuité de l'installation, nous recommandons la direction des graphiques selon les détourés du catalogue



Posa corretta / Correct laying

Pezzi speciali  
Special pieces



Battiscopa 4,5×60 ± 9,5

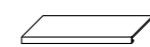

Gradino Costa Retta 33×120 ± 9,5

Chalk Nat/Ret 120×120 - 48"×48"



Gres fine porcellanato ad impasto colorato  
Tecnologia Digitale

Coloured-body fine porcelain stoneware  
Digital Technology

Feinsteinzeug aus farbiger Masse  
Digital Technologie

Grès cérame fin à pâte colorée  
Technologie Numérique

# Taupe

Per un risultato di posa ottimale si consiglia di prelevare le piastrelle da 5/6 scatole contemporaneamente.

For best installation results, we suggest taking the tiles from 5/6 boxes at the same time.

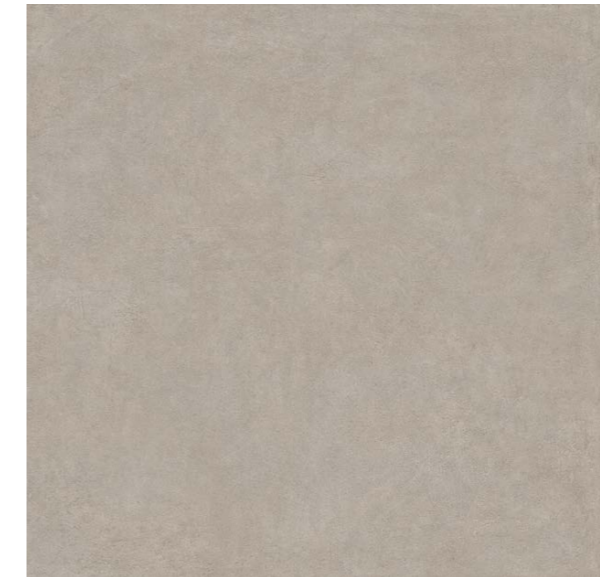

± 9

120×120 - 48"×48"

**05248** | Homey Taupe Nat/Ret

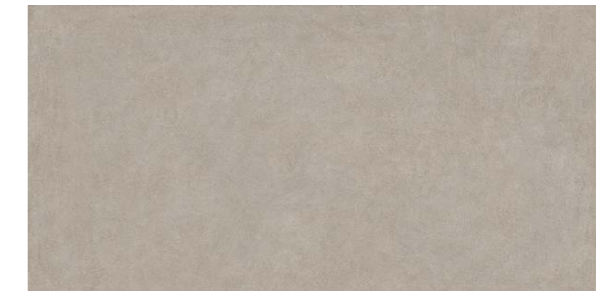

± 9,5

60×120 - 24"×48"

**05219** | Homey Taupe Nat/Ret

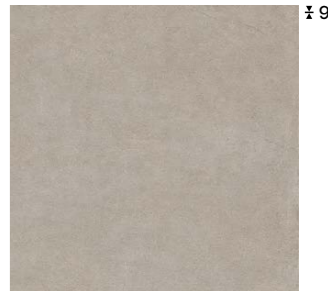

± 9,5

60×60 - 24"×24"

**05227** | Homey Taupe Nat/Ret



60×120 - 24"×48"

\* **05243** | Homey Rammed Cold Nat/Ret  
(mix 9 graphics)

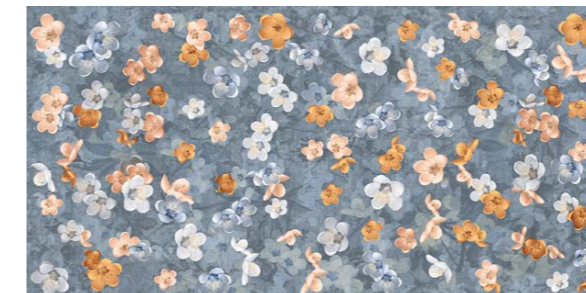

60×120 - 24"×48"

**05275** | Homey Bloom Blue Nat/Ret  
(mix 6 graphics)



± 9,5

10×60 - 4"×24"

**05280** | Homey Taupe Nat/Ret

\* Per la continuità di posa, si consiglia il verso della grafica come da minimale a catalogo  
For continuity of installation, we recommend the direction of the graphics as per picture in the catalogue  
Für eine kontinuierliche Verlegelinie empfehlen wir die Verlegung gemäß der Abbildung im Katalog  
Pour la continuité de l'installation, nous recommandons la direction des graphiques selon les détourés du catalogue



Posa corretta / Correct laying

Pezzi speciali  
Special pieces



Battiscopa 4,5×60 ± 9,5

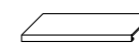

Gradino Costa Retta 33×120 ± 9,5



# Cotto

Per un risultato di posa ottimale si consiglia di prelevare le piastrelle da 5/6 scatole contemporaneamente.

For best installation results, we suggest taking the tiles from 5/6 boxes at the same time.

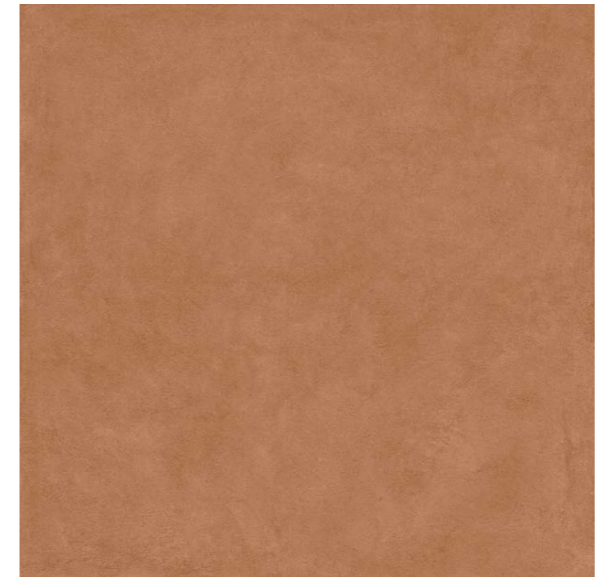

± 9

120x120 - 48"x48"

**05249** | Homey Cotto Nat/Ret



± 9,5

60x120 - 24"x48"

**05221** | Homey Cotto Nat/Ret



± 9,5

60x60 - 24"x24"

**05228** | Homey Cotto Nat/Ret



60x120 - 24"x48"

\* **05244** | Homey Rammed Warm Nat/Ret  
(mix 9 graphics)



± 9,5

10x60 - 4"x24"

**05281** | Homey Cotto Nat/Ret



60x120 - 24"x48"

**05241** | Homey Flower Cotto Nat/Ret



60x120 - 24"x48"

**05276** | Homey Bloom White Nat/Ret  
(mix 6 graphics)

\* Per la continuità di posa, si consiglia il verso della grafica come da minimale a catalogo  
For continuity of installation, we recommend the direction of the graphics as per picture in the catalogue  
Für eine kontinuierliche Verlegelinie empfehlen wir die Verlegung gemäß der Abbildung im Katalog  
Pour la continuité de l'installation, nous recommandons la direction des graphiques selon les détourés du catalogue

Pezzi speciali  
Special pieces



Battiscopa 4,5x60 ± 9,5

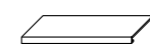

Gradino Costa Retta 33x120 ± 9,5



Gres fine porcellanato ad impasto colorato  
Tecnologia Digitale

Coloured-body fine porcelain stoneware  
Digital Technology

Feinsteinzeug aus farbiger Masse  
Digital Technologie

Grès cérame fin à pâte colorée  
Technologie Numérique

# Cloudy

Per un risultato di posa ottimale si consiglia di prelevare le piastrelle da 5/6 scatole contemporaneamente.

For best installation results, we suggest taking the tiles from 5/6 boxes at the same time.

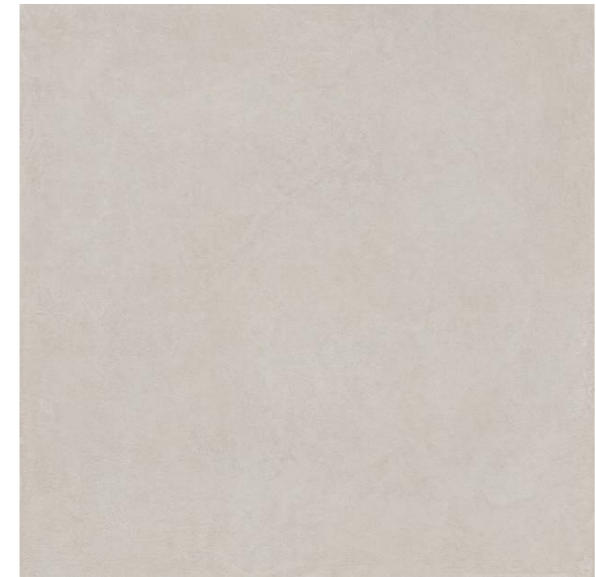

± 9

120×120 - 48"×48"

**05246** | Homey Cloudy Nat/Ret



± 9,5

60×120 - 24"×48"

**05217** | Homey Cloudy Nat/Ret

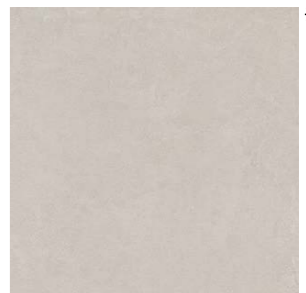

± 9,5

60×60 - 24"×24"

**05225** | Homey Cloudy Nat/Ret



60×120 - 24"×48"

\* **05243** | Homey Rammed Cold Nat/Ret  
(mix 9 graphics)

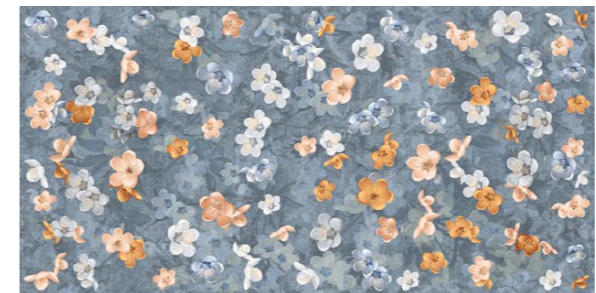

60×120 - 24"×48"

**05275** | Homey Bloom Blue Nat/Ret  
(mix 6 graphics)



± 9,5

10×60 - 4"×24"

**05278** | Homey Cloudy Nat/Ret

\* Per la continuità di posa, si consiglia il verso della grafica come da minimale a catalogo  
For continuity of installation, we recommend the direction of the graphics as per picture in the catalogue  
Für eine kontinuierliche Verlegelinie empfehlen wir die Verlegung gemäß der Abbildung im Katalog  
Pour la continuité de l'installation, nous recommandons la direction des graphiques selon les détournés du catalogue

Pezzi speciali  
Special pieces



Battiscopa 4,5×60 ± 9,5

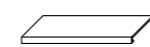

Gradino Costa Retta 33×120 ± 9,5



Gres fine porcellanato ad impasto colorato  
Tecnologia Digitale

Coloured-body fine porcelain stoneware  
Digital Technology

Feinsteinzeug aus farbiger Masse  
Digital Technologie

Grès cérame fin à pâte colorée  
Technologie Numérique

# Dove

Per un risultato di posa ottimale si consiglia di prelevare le piastrelle da 5/6 scatole contemporaneamente.

For best installation results, we suggest taking the tiles from 5/6 boxes at the same time.

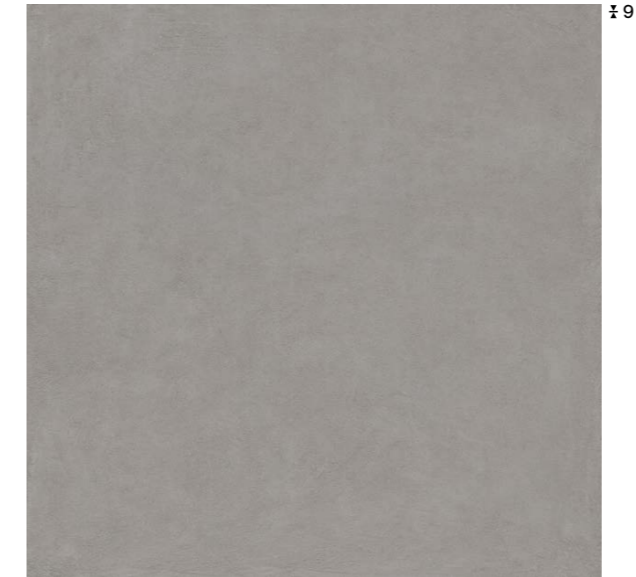

± 9

120×120 - 48"×48"

**05247** | Homey Dove Nat/Ret



± 9,5

60×120 - 24"×48"

**05218** | Homey Dove Nat/Ret



± 9,5

60×60 - 24"×24"

**05226** | Homey Dove Nat/Ret



60×120 - 24"×48"

\* **05243** | Homey Rammed Cold Nat/Ret  
(mix 9 graphics)



60×120 - 24"×48"

**05242** | Homey Flower Chalk Nat/Ret



± 9,5

10×60 - 4"×24"

**05279** | Homey Dove Nat/Ret

\* Per la continuità di posa, si consiglia il verso della grafica come da minimale a catalogo  
For continuity of installation, we recommend the direction of the graphics as per picture in the catalogue  
Für eine kontinuierliche Verlegelinie empfehlen wir die Verlegung gemäß der Abbildung im Katalog  
Pour la continuité de l'installation, nous recommandons la direction des graphiques selon les détournés du catalogue

Pezzi speciali  
Special pieces



Battiscopa 4,5×60 ± 9,5

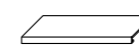

Gradino Costa Retta 33×120 ± 9,5





Gres fine porcellanato ad impasto colorato  
Tecnologia Digitale

Coloured-body fine porcelain stoneware  
Digital Technology

Feinsteinzeug aus farbiger Masse  
Digital Technologie

Grès cérame fin à pâte colorée  
Technologie Numérique

# Sage

Per un risultato di posa ottimale si consiglia di prelevare le piastrelle da 5/6 scatole contemporaneamente.

For best installation results, we suggest taking the tiles from 5/6 boxes at the same time.



± 9,5

60×120 - 24"×48"

**05222** | Homey Sage Nat/Ret



± 9,5

60×60 - 24"×24"

**05229** | Homey Sage Nat/Ret



± 9,5

10×60 - 4"×24"

**05282** | Homey Sage Nat/Ret



60×120 - 24"×48"

\* **05243** | Homey Rammed Cold Nat/Ret  
(mix 9 graphics)



60×120 - 24"×48"

**05276** | Homey Bloom White Nat/Ret  
(mix 6 graphics)

\* Per la continuità di posa, si consiglia il verso della grafica come da minimale a catalogo  
For continuity of installation, we recommend the direction of the graphics as per picture in the catalogue  
Für eine kontinuierliche Verlegelinie empfehlen wir die Verlegung gemäß der Abbildung im Katalog  
Pour la continuité de l'installation, nous recommandons la direction des graphiques selon les détourés du catalogue

Pezzi speciali  
Special pieces



Battiscopa 4,5×60 ± 9,5

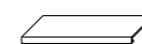

Gradino Costa Retta 33×120 ± 9,5



Gres fine porcellanato ad impasto colorato  
Tecnologia Digitale

Coloured-body fine porcelain stoneware  
Digital Technology

Feinsteinzeug aus farbiger Masse  
Digital Technologie

Grès cérame fin à pâte colorée  
Technologie Numérique

# Berry

Per un risultato di posa ottimale si consiglia di prelevare le piastrelle da 5/6 scatole contemporaneamente.

For best installation results, we suggest taking the tiles from 5/6 boxes at the same time.



± 9,5

60x120 - 24"x48"

05223 | Homey Berry Nat/Ret



± 9,5

60x60 - 24"x24"

05231 | Homey Berry Nat/Ret



± 9,5

10x60 - 4"x24"

05283 | Homey Berry Nat/Ret



60x120 - 24"x48"

05241 | Homey Flower Cotto Nat/Ret

Pezzi speciali  
Special pieces



Battiscopa 4,5x60 ± 9,5

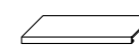

Gradino Costa Retta 33x120 ± 9,5

# Homey Stripes Glossy



30x60 - 12"x24"  
05234 | Homey Stripes White Glossy Ret



30x60 - 12"x24"  
05235 | Homey Stripes Mustard Glossy Ret



30x60 - 12"x24"  
05233 | Homey Stripes Green Glossy Ret

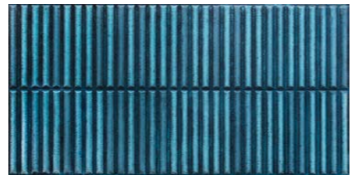

30x60 - 12"x24"  
05232 | Homey Stripes Blue Glossy Ret

# Homey Stripes Mat



30x60 - 12"x24"  
05236 | Homey Stripes White Mat Ret



30x60 - 12"x24"  
05237 | Homey Stripes Powder Mat Ret



30x60 - 12"x24"  
05238 | Homey Stripes Clay Mat Ret



30x60 - 12"x24"  
05239 | Homey Stripes Grey Mat Ret

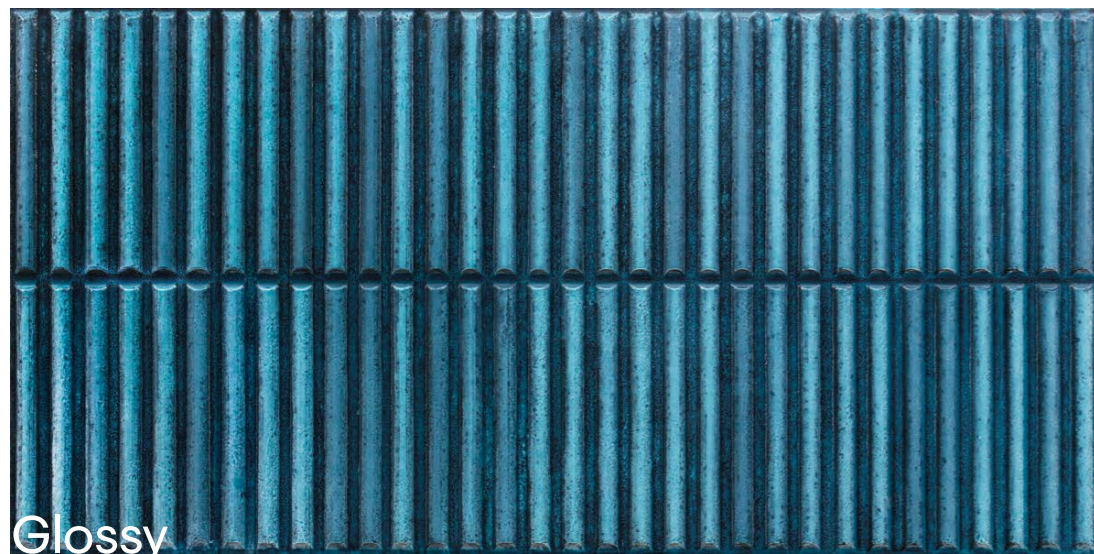

Glossy

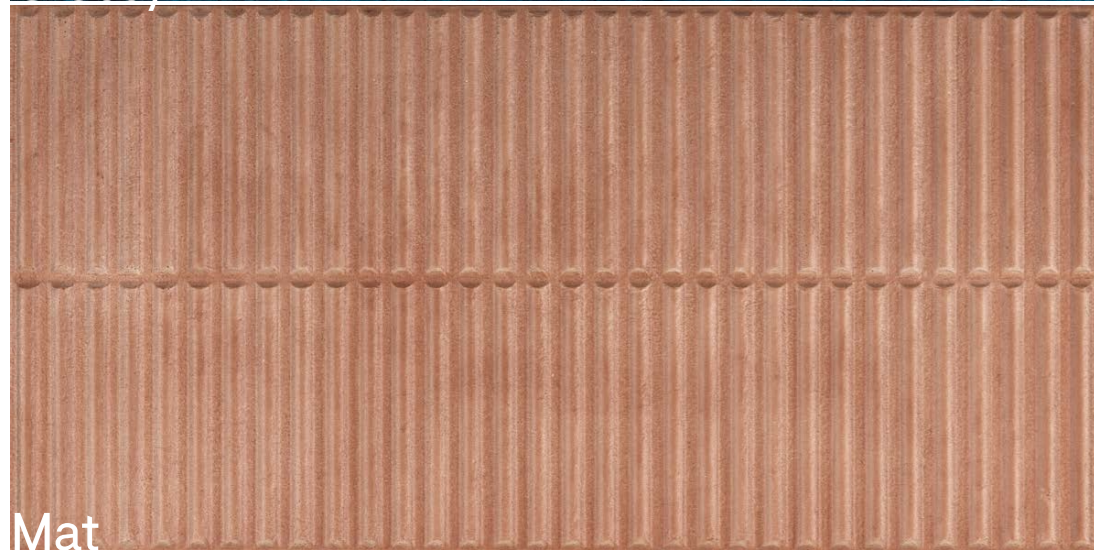

Mat

# Abbinabilità

Matching  
Passende Kombinationen  
Coloris Compatibles



Stripes White Glossy



Taupe



Cotto

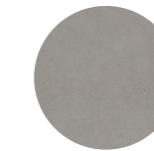

Dove



Sage



Berry



Stripes Mustard Glossy



Taupe

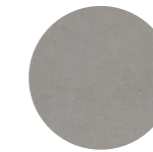

Dove



Berry

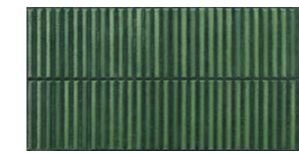

Stripes Green Glossy



Chalk



Taupe



Cotto

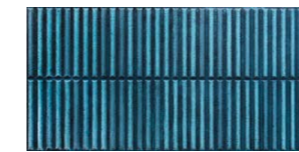

Stripes Blue Glossy



Chalk



Taupe



Cotto



Cloudy



Stripes White Mat



Taupe

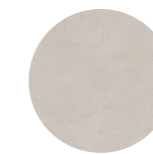

Cloudy

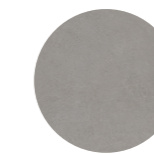

Dove

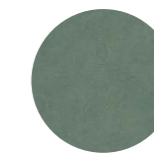

Sage



Berry

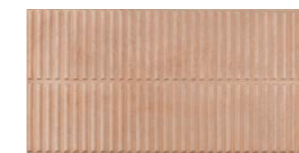

Stripes Powder Mat



Cotto



Berry

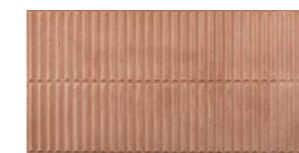

Stripes Clay Mat



Chalk



Cotto



Sage



Berry

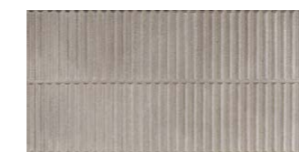

Stripes Grey Mat



Chalk



Cloudy

Solorovere



Pure



Flamed

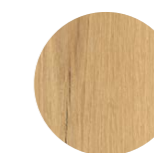

Loft



Vintage

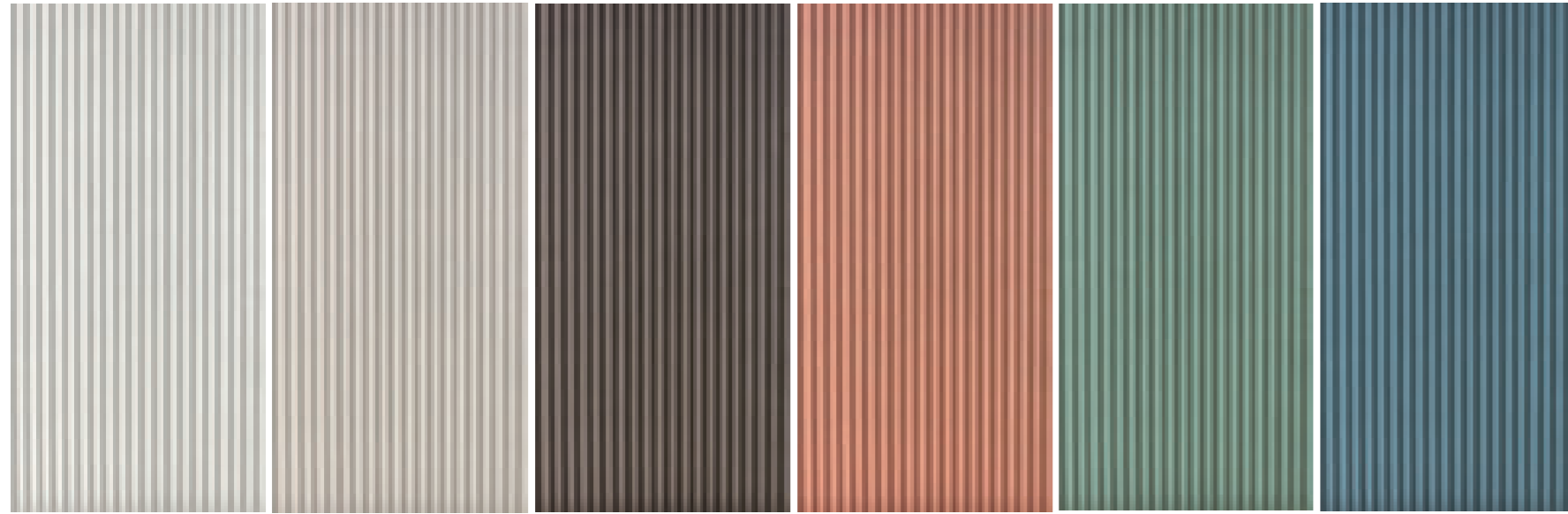

60x120 - 24"x48" **05981** | Homey Cannelé Cotton Ret  
60x120 - 24"x48" **05982** | Homey Cannelé Hemp Ret  
60x120 - 24"x48" **05986** | Homey Cannelé Shadow Ret  
60x120 - 24"x48" **05983** | Homey Cannelé Rose Ret  
60x120 - 24"x48" **05984** | Homey Cannelé Laurel Ret  
60x120 - 24"x48" **05985** | Homey Cannelé Denim Ret

## Cannelé



60x120  
**05981** | Homey Cannelé Cotton Ret



60x120  
**05986** | Homey Cannelé Shadow Ret



60x120  
**05984** | Homey Cannelé Laurel Ret

## Abbinabilità

Matching  
Passende Kombinationen  
Coloris Compatibles



Cotto Dove Sage Berry



Chalk Cloudy

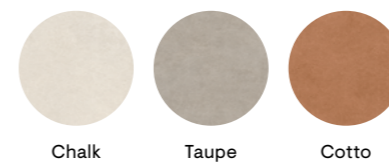

Chalk Taupe Cotto

### Solorovere



Pure Flamed Loft Vintage

## Cannelé



60x120  
**05982** | Homey Cannelé Hemp Ret



60x120  
**05983** | Homey Cannelé Rose Ret

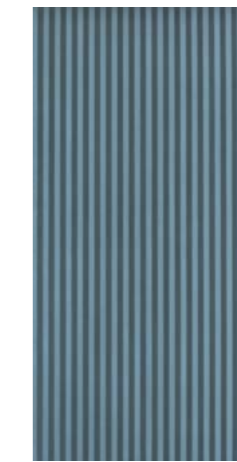

60x120  
**05985** | Homey Cannelé Denim Ret

## Abbinabilità

Matching  
Passende Kombinationen  
Coloris Compatibles



Chalk Cotto Berry



Chalk Dove



Chalk Taupe Cotto Cloudy

### Solorovere







Pure Flamed Loft Vintage

# Riepilogo Gamma Stucchi consigliati

Collection / Serie / Gamme

Recommended grouts / Joints recommandés /Empfohlene Fugen

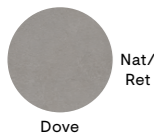
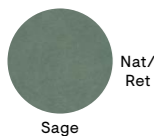
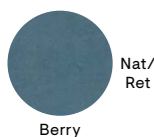





| Formati<br>Sizes   | Formati<br>Sizes   |                   |                  |                 | DIN<br>5130 | DIN<br>51097 | DCCF | BS EN<br>7976-2 | AS<br>4586<br>2013 | Stucchi Consigliati<br>Recommended grouts<br>Joints recommandés<br>Empfohlene Fugen |                                |
|--|--------------------|-------------------|------------------|-----------------|-------------|--------------|------|-----------------|--------------------|---|--------------------------------|
|  | 120x120<br>48"x48" | 60x120<br>24"x48" | 60x60<br>24"x24" | 10x60<br>4"x24" |             |              |      |                 |                    |   |                                |
|  | 120x120<br>48"x48" | 60x120<br>24"x48" | 60x60<br>24"x24" | 10x60<br>4"x24" | DIN<br>5130 | DIN<br>51097 | DCCF | BS EN<br>7976-2 | AS<br>4586<br>2013 |   |                                |
|  | 9                  | 9,5               | 9,5              | 9,5             |             |              |      |                 |                    |   |                                |
|  Nat/<br>Ret<br>Chalk    | 05245              | 05216             | 05224            | 05277           | V2          | R10          | B    | >0.42           | wet,<br>dry<br>>36 | P3  | Mapei 111                      |
|  Nat/<br>Ret<br>Taupe   | 05248              | 05219             | 05227            | 05280           | V2          | R10          | B    | >0.42           | wet,<br>dry<br>>36 | P3  | 50% Mapei 111<br>50% Mapei 112 |
|  Nat/<br>Ret<br>Cotto  | 05249              | 05221             | 05228            | 05281           | V2          | R10          | B    | >0.42           | wet,<br>dry<br>>36 | P3  | Mapei 142                      |
|  Nat/<br>Ret<br>Cloudy | 05246              | 05217             | 05225            | 05278           | V2          | R10          | B    | >0.42           | wet,<br>dry<br>>36 | P3  | Mapei 111                      |
|  Nat/<br>Ret<br>Dove   | 05247              | 05218             | 05226            | 05279           | V2          | R10          | B    | >0.42           | wet,<br>dry<br>>36 | P3  | Mapei 112                      |
|  Nat/<br>Ret<br>Sage   |                    | 05222             | 05229            | 05282           | V2          | R10          | B    | >0.42           | wet,<br>dry<br>>36 | P3  | Kerakoll 19                    |
|  Nat/<br>Ret<br>Berry  |                    | 05223             | 05231            | 05283           | V2          | R10          | B    | >0.42           | wet,<br>dry<br>>36 | P3  | Kerakoll 16                    |

**Stucchi Consigliati**  
Recommended grouts  
Joints recommandés  
Empfohlene Fugen

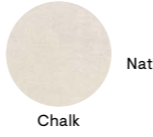
| Decori<br>Decors | Decori<br>Decors                  |                                   |                                  |                                  |                                  |                                 |
|------------------|-----------------------------------|-----------------------------------|----------------------------------|----------------------------------|----------------------------------|---------------------------------|
|                  | Flower Cotto<br>60x120<br>24"x48" | Flower Chalk<br>60x120<br>24"x48" | Rammed Warm<br>60x120<br>24"x48" | Rammed Cold<br>60x120<br>24"x48" | Bloom White<br>60x120<br>24"x48" | Bloom Blue<br>60x120<br>24"x48" |
|                  | 9,5                               | 9,5                               | 9,5                              | 9,5                              | 9,5                              | 9,5                             |
|                  |                                   | 05242                             | 05244                            | 05243                            | 05276                            | 05275                           |
|                  |                                   |                                   | 05244                            | 05243                            |                                  | 05275                           |
|                  | 05241                             |                                   | 05244                            | 05243                            | 05276                            |                                 |
|                  |                                   |                                   |                                  | 05243                            |                                  | 05275                           |
|                  |                                   | 05242                             |                                  | 05243                            | 05276                            | 05275                           |
|                  |                                   | 05242                             |                                  |                                  | 05276                            |                                 |
|                  | 05241                             |                                   |                                  |                                  |                                  |                                 |

|             |           |           |           |           |             |
|-------------|-----------|-----------|-----------|-----------|-------------|
| Kerakoll 34 | Mapei 111 | Mapei 133 | Mapei 111 | Mapei 111 | Kerakoll 14 |
|-------------|-----------|-----------|-----------|-----------|-------------|

Strutture 3D  
3D Structures

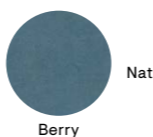
| Strutture 3D<br>3D Structures   | Strutture 3D<br>3D Structures               |   |   |  |  |   |   |   |
|---|---|---|---|--|--|---|---|---|
|   | Stripes White<br>Glossy<br>30x60<br>12"x24" | Stripes Mustard<br>Glossy<br>30x60<br>12"x24" | Stripes Green<br>Glossy<br>30x60<br>12"x24" | Stripes Blue<br>Glossy<br>30x60<br>12"x24" | Stripes White<br>Mat<br>30x60<br>12"x24" | Stripes Powder<br>Mat<br>30x60<br>12"x24" | Stripes Clay<br>Mat<br>30x60<br>12"x24" | Stripes Grey<br>Mat<br>30x60<br>12"x24" |
|   | 9,5   | 9,5   | 9,5   | 9,5  | 9,5                                      | 9,5                                       | 9,5                                     |   |
|  Nat/<br>Ret<br>Chalk    |   |   | 05233                                       | 05232                                      |  |   | 05238                                   | 05239                                   |
|  Nat/<br>Ret<br>Taupe   | 05234                                       | 05235   | 05233                                       | 05232                                      | 05236                                    |   |   |   |
|  Nat/<br>Ret<br>Cotto  | 05234                                       |   | 05233                                       | 05232                                      |  | 05237                                     | 05238                                   |   |
|  Nat/<br>Ret<br>Cloudy |   |   |   | 05232                                      | 05236                                    |   | 05239                                   |   |
|  Nat/<br>Ret<br>Dove   | 05234                                       | 05235   |   |  | 05236                                    |   |   |   |
|  Nat/<br>Ret<br>Sage   | 05234                                       |   |   |  | 05236                                    |   | 05238                                   |   |
|  Nat/<br>Ret<br>Berry  | 05234                                       | 05235   |   |  | 05236                                    | 05237                                     | 05238                                   |   |

**Stucchi Consigliati**  
Recommended grouts  
Joints recommandés  
Empfohlene Fugen

|           |             |                                  |             |           |           |             |           |
|-----------|-------------|----------------------------------|-------------|-----------|-----------|-------------|-----------|
| Mapei 111 | Kerakoll 30 | 50% Kerakoll 19<br>50% Mapei 120 | Kerakoll 16 | Mapei 111 | Mapei 141 | Kerakoll 34 | Mapei 112 |
|-----------|-------------|----------------------------------|-------------|-----------|-----------|-------------|-----------|

Pezzi Speciali  
Special Pieces

| Pezzi Speciali<br>Special Pieces | Pezzi Speciali<br>Special Pieces            |                                    |
|----------------------------------|---|------------------------------------|
|                                  | Gradino<br>Costa Retta<br>33x120<br>13"x48" | Battiscopa<br>4,5x60<br>1 3/4"x24" |
|                                  | 9,5   | 9,5                                |
|                                  | 05264                                       | 05256                              |
|                                  | 05267                                       | 05259                              |
|                                  | 05268                                       | 05261                              |
|                                  | 05265                                       | 05257                              |
|                                  | 05266                                       | 05258                              |
|                                  | 05269                                       | 05262                              |
|                                  | 05271                                       | 05263                              |

# Riepilogo Gamma Stucchi consigliati

Collection / Serie / Gamme

Recommended grouts / Joints recommandés /Empfohlene Fugen

|  |         | Strutture 3D<br>3D Structures       |                                   |                                     |                                   |                                     |                                    |
|--|---------|-------------------------------------|-----------------------------------|-------------------------------------|-----------------------------------|-------------------------------------|------------------------------------|
|  |         |                                     |                                   |                                     |                                   |                                     |                                    |
|  |         | Canneté Cotton<br>60x120<br>24"x48" | Canneté Hemp<br>60x120<br>24"x48" | Canneté Shadow<br>60x120<br>24"x48" | Canneté Rose<br>60x120<br>24"x48" | Canneté Laurel<br>60x120<br>24"x48" | Canneté Denim<br>60x120<br>24"x48" |
|  |         | ± 9,5                               | ± 9,5                             | ± 9,5                               | ± 9,5                             | ± 9,5                               | ± 9,5                              |
|  | Nat/Ret |                                     | 05982                             | 05986                               | 05983                             | 05984                               | 05985                              |
|  | Nat/Ret | 05981                               |                                   |                                     |                                   | 05984                               | 05985                              |
|  | Nat/Ret | 05981                               | 05982                             |                                     |                                   | 05984                               | 05985                              |
|  | Nat/Ret |                                     |                                   | 05986                               |                                   |                                     | 05985                              |
|  | Nat/Ret | 05981                               |                                   |                                     | 05983                             |                                     |                                    |
|  | Nat/Ret | 05981                               |                                   |                                     |                                   |                                     |                                    |
|  | Nat/Ret | 05981                               | 05982                             |                                     |                                   |                                     |                                    |

**Stucchi Consigliati**  
Recommended grouts  
Joints recommandés  
Empfohlene Fugen

|           |           |           |                                  |            |             |
|-----------|-----------|-----------|----------------------------------|------------|-------------|
| Mapei 103 | Mapei 123 | Mapei 119 | 50% Kerakoll 40<br>50% Mapei 110 | Kerakoll19 | kerakoll 15 |
|-----------|-----------|-----------|----------------------------------|------------|-------------|

# Imballi

Packing  
Verpackung  
Emballage

| Formati<br>Sizes                                |   | ± MM | Pezzi Scatola<br>Pieces/Box<br>Stck/Karton<br>Carreaux/Boîte | Mq/Scatola<br>Sqmt/Box<br>Qm/Karton<br>M2/Boîte | Kg/Scatola<br>Kgs/Box<br>Kg/Karton<br>Kg/Boîte | Scatole/Paletta<br>Boxes/Pallet<br>Karton/Palette<br>Boîte/Palette | Mq/Paletta<br>Sqmt/Pallet<br>Qm/Pallet<br>M2/Palette | Kg/Paletta<br>Kgs/Pallet<br>Kg/Pallet<br>Kg/Palette | Formato Paletta<br>Size Pallet<br>Format Pallet<br>Dim. Palette |
|---|---|------|--|---|--|--|--|---|---|
| 120x120 (48"x48")<br>Nat/Ret                    | P | 9    | 2  | 2,880   | 58,00  | 22   | 63,36  | 1276,00   | 135x122x68  |
| 60x120 (24"x48")<br>Nat/Ret                     | P | 9,5  | 2  | 1,440   | 31,00  | 30   | 43,20  | 930,00  | 120x82x75   |
| 60x60 (24"x24")<br>Nat/Ret                      | P | 9,5  | 4  | 1,440   | 29,00  | 32   | 46,08  | 928,00  | 120x80x75   |
| 10x60 (4"x24")<br>Nat/Ret                       | P | 9,5  | 10   | 0,600   | 12,50  | 72   | 43,20  | 900,00  | 120x80x75   |
| 30x60 (12"x24")<br>Stripes Nat/Ret              | P | 9,5  | 7  | 1,260   | 26,30  | 32   | 40,32  | 841,60  | 120x80x75   |
| 60x120 (24"x48")<br>Canneté Ret                 | P | 9,5  | 1  | 0,72  | 15,50  | 60   | 43,2   | 930,00  | 120x82x75   |
| 60x120 (24"x48")<br>Rammed Nat/Ret              | P | 9,5  | 2  | 1,440   | 31,00  | 30   | 43,20  | 930,00  | 122x82x75   |
| 60x120 (24"x48")<br>Bloom Nat/Ret               | P | 9,5  | 2  | 1,440   | 31,00  | 30   | 43,20  | 930,00  | 122x82x75   |
| 60x120 (24"x48")<br>Flower Nat/Ret              | P | 9,5  | 2  | 1,440   | 31,00  | 30   | 43,20  | 930,00  | 122x82x75   |
| Pezzi Speciali / Special Pieces                 |   |      |  |   |  |  |  |   |   |
| 33x120 (13"x48")<br>Gradino Costa Retta Nat/Ret | P | 9,5  | 2  | 0,792   | 18,50  | 20   | -  | -   | -   |
| 4,5x60 (1 3/4"x24")<br>Battiscopa Nat/Ret       | P | 9,5  | 14   | 0,378<br>m.l. 8,40                              | 8,00   | 80   | -  | -   | -   |

Tutti i formati sono nominali.

Gli spessori riportati in questo catalogo sono nominali e possono variare a seconda dei formati e delle finiture.

I colori e le caratteristiche estetiche dei prodotti sono quanto più possibile vicini a quelli reali, nei limiti consentiti dai processi di stampa.

All sizes are nominal.

The thickness mentioned on this catalogue are nominal and can be different according to the sizes and the finishes.

The colours and appearance features of the products are as close as possible to reality, within the limitation of the printing process.

Die Formate sind Nennwerte.

Die in diesem Katalog angegebenen Fliesenstärke sind nominal und können, je nach Format oder Oberfläche, verschieden sein.

Die Farben und die ästhetischen Eigenschaften der Produkte entsprechen der Wirklichkeit, innerhalb den von dem Druckverfahren erlaubten Grenzen.

Tous les formats sont nominaux.

Les épaisseurs reportées sur ce catalogue sont nominales et peuvent varier suivant les formats et les finitions.

Les couleurs et les caractéristiques esthétiques sont fidèles aux couleurs et caractéristiques réelles dans les limites des procédés d'impression.

# Pezzi Speciali

Special pieces  
Formstücke  
Pièces spéciales

## Battiscopa Nat/Ret 4,5×60 – 1¼”×24” ± 9,5

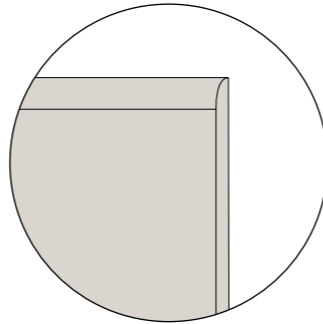
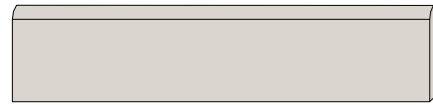

## Gradino Costa Retta Nat/Ret 33×120 – 13”×48” ± 9,5 (costa retta ottenuto per taglio e incollaggio - obtained by cutting ang gluing)

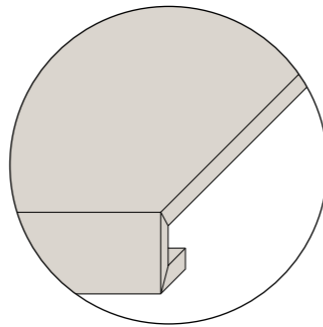
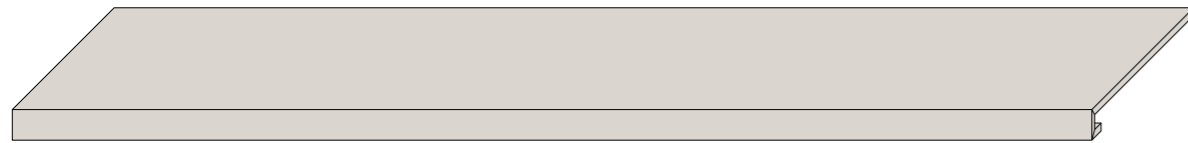

# Norme per la posa e la manutenzione

## Installation and maintenance instructions

- Per i prodotti rettificati consigliamo una fuga di 2 mm per un migliore risultato di posa.
- Per una migliore resa estetica Piemme consiglia stuccature colorate in tinta con le piastrelle. Verificare, prima dell'utilizzo, la compatibilità ed idoneità dei riempitivi per fughe con il prodotto ceramico.
- Rimuovere le eccedenze dei riempitivi per fughe quando gli stessi sono ancora freschi.
- Attenersi scrupolosamente alle istruzioni indicate dai produttori dei riempitivi per fughe.
- Per eliminare completamente i residui di posa, che potrebbero compromettere la manutenzione ordinaria e le caratteristiche del prodotto, a posa ultimata, procedere con la pulizia utilizzando prodotti adeguati, a base Acida max 3%, rispettando le indicazioni del produttore. Osservare assolutamente i limiti di tempo indicati nelle istruzioni: un contatto troppo pro lungato con questi prodotti potrebbe provocare il danneggiamento della superficie.
- Gli eventuali aloni che si dovessero presentare dopo la posa di materiali lappati o levigati si potranno facilmente eliminare utilizzando un prodotto idoneo, a base Alcalina.
- Decorati realizzati con smalti e metalli preziosi è indispensabile proteggere la superficie durante la posa, non utilizzare assolutamente prodotti abrasivi e/o acidi, ma solo acqua e sapone neutro. Il produttore non risponde di eventuali danni a questi preziosi materiali causati da "sfregamenti" durante la posa in opera. Per nessun motivo saranno accettate contestazioni relative a materiale posato.

| TIPO DI SPORCO  | INDICAZIONI PER LA PULIZIA |
|---|----------------------------|
| Birra, Caffè, Gelato, Vino<br>Gomma Pneumatico, Grassi vegetali e animali, Inchiostri, Lampostil Olii Meccanici, Residui di scotch Olio di lino, PennarelloResine Smalti, Tintura per capelli | Prodotti a Base Alcalina   |
| Cera protettiva anti-abrasione, Depositi calcarei, Macchie di ruggine   | Prodotti a Base Acida      |
| Cera di candela, Residui di scotch  | Solventi                   |
| Per ulteriori informazioni specifiche consultare l'area tecnica sul sito Piemme: <a href="http://www.ceramichepiemme.it">www.ceramichepiemme.it</a>   |                            |

- For better installation results of rectified products, we suggest 2 mm joint.
- For a better aesthetic finish, Piemme recommends using jointing colours that match the tiles.
- Please check, before using, the compatibility and suitability of grouting material with the ceramic tile.
- Clean away the excess of grouting materials while they are still fresh.
- Follow carefully the instructions pointed out by the producers of tile grouting materials.
- To completely eliminate installation residues, which could negatively affect routine maintenance and product characteristics once installation has terminated, proceed to clean using adequate products, with max. 3% Acid base, following the manufacturer's instructions. Always closely abide by the time limits indicated in the instructions: prolonged contact with these products may cause damage to the surface.
- Any rims that appear after installing lapped or polished materials can be easily eliminated using a suitable Alkaline-based product.
- With regard to the use of ceramic materials outdoors, while once more reiterating that Piemme porcelain stoneware products are frost-proof, in compliance with applicable European standards EN 14411/ISO 13006-ISO 10545.12, a number of fundamental procedures must be followed for outdoor installation, suitable for making the aforementioned floors resistant to frost. The most important aspects are: suitable gradients, waterproofing, expansion joints, and the use of suitable installation materials.
- Decorations made with glazes and precious metals It is most important to protect the surface during installation. Never use abrasive and/or acid products, only water and neutral soap. The manufacturer disclaims liability in case of any damage to these precious materials caused by "rubbing" during installation. Under no circumstances will disputes be accepted relating to the installed material.

| TYPE OF STAIN   | CLEANING SUGGESTIONS     |
|---|--------------------------|
| beer, coffee, wine, ice cream vegetable and animal fats, rubber, remains of scotch tape, grease from machines, linseed oil, felt tip pens, paints, inks, hair dye | Alkaline-based detergent |
| protective anti-abrasion wax, calcareous residuals, rust stains   | Acid-based detergent     |
| candle wax, remains of scotch-tape  | Solvents                 |

For further specific details please visit the technical area on Piemme website: [www.ceramichepiemme.it](http://www.ceramichepiemme.it)

# Caratteristiche Tecniche

Technical characteristics  
Technische daten  
Caracteristiques techniques

CLASSIFICAZIONE SECONDO NORME EN 14411 BI<sub>A</sub> – ISO 13006 – CLASSIFICATION IN ACCORDANCE WITH EN 14411 BI<sub>A</sub> – ISO 13006  
KLASSIFIZIERUNG GEMÄSS NORMEN EN 14411 BI<sub>A</sub> – ISO 13006 – CLASSIFICATION SELON LES NORMES EN 14411 BI<sub>A</sub> – ISO 13006

| CARATTERISTICA TECNICA<br>TECHNICAL CHARACTERISTIC<br>TECHNISCHE DATE<br>CARACTÉRISTIQUE TECHNIQUE   | NORMA<br>NORM<br>NORM<br>NORME | VALORE PRESCRITTO<br>VALUE REQUIRED<br>NORMVORGABE<br>VALEUR PRESCRIPTE  | VALORE MEDIO<br>MEAN VALUE<br>MITTELWERT<br>VALEUR MOYENNE | NORMA<br>NORM<br>NORM<br>NORME         | VALORE MEDIO<br>MEAN VALUE<br>MITTELWERT<br>VALEUR MOYENNE |
|--|--------------------------------|--|--|--|--|
|  |                                |  | CERAMICHE PIEMME<br>FLOOR AND ROOF                         |  | CERAMICHE PIEMME<br>FLOOR AND ROOF                         |
| LUNGHEZZA E LARGHEZZA<br>LENGHT AND WIDTH / LÄNGE UND BREITE / LONGUEUR ET LARGEUR   |                                | ±0.6% (±2.00 MM)   |  |  |  |
| SPESORE<br>THICKNESS / STÄRKE / ÉPAISSEUR  |                                | ±5% (±0.5 MM)  |  |  |  |
| RETTILINEITÀ LATI<br>WARPAGES OF EDGES / GERADHEIT DER KANTEN / RÉCTITUDE DES ARÊTES   | ISO 10545.2                    | ±0.5% (±1.5 MM)  | CONFORME<br>IN ACCORDANCE<br>ERFÜLLT<br>CONFORME           | ASTM C-499<br>ASTM C-485<br>ASTM C-502 | IN ACCORDANCE  |
| ORTOGONALITÀ<br>WEDGING / RECHTWINKLIGKEIT / ORTHOGONALITÉ   |                                | ±0.5% (±2.00 MM)   |  |  |  |
| PLANARITÀ<br>FLATNESS / PLANITÄT / PLANIMÉTRIE   |                                | ±0.5% (±2.00 MM)   |  |  |  |
| ASSORBIMENTO % D'ACQUA<br>WATER ABSORPTION<br>WASSERANNAHME %<br>ABSORPTION D'EAU %  | ISO 10545.3                    | ≤ 0.5%   | CONFORME<br>IN ACCORDANCE<br>ERFÜLLT<br>CONFORME           | ASTM C-373                             | IN ACCORDANCE  |
| RESISTENZA ALLA FLESSIONE<br>BENDING STRENGTH<br>BIEGEZUGFESTIGKEIT<br>RÉSISTANCE À LA FLEXION   | ISO 10545.4                    | Modulus of rupture (average):<br>R ≥ 35N/mm <sup>2</sup><br>Breaking strength for thickness ≥ 7.5 mm<br>S > 1300 N                           | CONFORME<br>IN ACCORDANCE<br>ERFÜLLT<br>CONFORME           | ASTM C-648<br>250 LBS OR GREATER       | IN ACCORDANCE  |
| DILATAZIONE TERMICA LINEARE TRA 20° E 100° C<br>LINEAR THERMAL EXPANSION BETWEEN 20° AND 100° C<br>LINEARE WÄRMEAUSENDENUNG ZWISCHEN 20° UND 100° C<br>DILATATION THERMIQUE LINEAIRE ENTRE 20° ET 100° C | ISO 10545.8                    | SECONDO I DATI DEL COSTRUTTORE<br>ACCORDING TO BUILDER'S SPECIFICATIONS<br>LAUT ANGABEN DES HERSTELLERS<br>SELON LES ELEMENTS DU COSTRUCTEUR | ≈ 7X10 <sup>-6</sup> C <sup>-1</sup>                       |  |  |
| RESISTENZA AGLI SBALZI TERMICI<br>THERMAL SHOCK RESISTANCE<br>TEMPERATURWECHSELBESTÄNDIGKEIT<br>RÉSISTANCE AUX ÉCARTS DE TEMPÉRATURE   | ISO 10545.9                    | RICHIESTA<br>REQUEST<br>BITTE<br>DEMANDE   | RESISTENTE<br>RESISTANT<br>WIDERSTEHEND<br>RÉSISTANT       |  |  |
| RESISTENZA AL GELO<br>FROST RESISTANCE<br>FROSTBESTÄNDIGKEIT<br>RÉSISTANCE AU GEL  | ISO 10545.12                   | RICHIESTA<br>REQUEST<br>BITTE<br>DEMANDE   | RESISTENTE<br>RESISTANT<br>WIDERSTEHEND<br>RÉSISTANT       | ASTM C-1026                            | IN ACCORDANCE  |
| RESISTENZA ALL'ATTACCO CHIMICO<br>RESISTANCE TO CHEMICAL ATTACK<br>BESTÄNDIGKEIT GEGEN CHEMIKALIEN<br>RÉSISTANCE À L'ATTAQUE CHIMIQUE  | ISO 10545.13                   | SECONDO I DATI DEL COSTRUTTORE<br>ACCORDING TO BUILDER'S SPECIFICATIONS<br>LAUT ANGABEN DES HERSTELLERS<br>SELON LES ELEMENTS DU COSTRUCTEUR | RESISTENTE<br>RESISTANT<br>WIDERSTEHEND<br>RÉSISTANT       | ASTM C-650                             | IN ACCORDANCE  |
| RESISTENZA DEI COLORI ALLA LUCE<br>COLOURS RESISTANCE TO LIGHT<br>LICHTBESTÄNDIGKEIT<br>RÉSISTANCE DES COULEURS À LA LUMIÈRE   | DIN 51094                      | NESSUNA ALTERAZIONE<br>NO ALTERATION<br>KEINE VERÄNDERUNG<br>AUCUNE ALTERATION   | CONFORME<br>IN ACCORDANCE<br>ERFÜLLT<br>CONFORME           |  |  |
| RESISTENZA ALLE MACCHIE<br>STAIN RESISTANCE<br>FLECKENFESTIGKEIT<br>RÉSISTANCE AUX TACHES  | ISO 10545.14                   | ≥ CLASSE 3<br>METODO DI PROVA DISPONIBILE<br>TEST METHOD AVAILABLE<br>VERFÜGBARE PRÜFMETHODE<br>METHODE D'ESSAI DISPONIBLE                   | CONFORME<br>IN ACCORDANCE<br>ERFÜLLT<br>CONFORME           |  |  |
| RESISTENZA ALLO SCIVOLAMENTO<br>SLIP-RESISTANCE<br>RUTSCHSICHERHEIT<br>RÉSISTANCE AU GLISSEMENT  | DIN 51130 *                    | 9 ≤ R ≤ 13   | NAT  | R10                                    | ASTM C-1028 * COF<br>≥ 0.6 DRY<br>≥ 0.6 WET                |
|  | DIN 51097 *                    | A,B,C  | NAT  | B                                      | ANSI *<br>137.1-2012 DCOF<br>> 0.42 WET                    |
| PENDULUM SLIP TEST   | BS EN 7976-2*                  | > 36 DRY<br>> 36 WET   | NAT  | Wet, Dry > 36                          | AS 4586:<br>2013<br>CLASS                                  |

\*TRATTANDOSI DI NORMATIVE NAZIONALI, I METODI DI PROVA, I REQUISITI E LE CLASSIFICAZIONI VARIANO DA PAESE A PAESE. IL VALORE ATTESO DALLA RESISTENZA ALLO SCIVOLAMENTO DELLA PRODUZIONE DI INDUSTRIE CERAMICHE PIEMME S.P.A., PUÒ VARIARE IN BASE AL LOTTO PRODUTTIVO. SPECIFICA DOCUMENTAZIONE È DISPONIBILE SU RICHIESTA. TEST METHODS, REQUIREMENTS AND CLASSIFICATIONS DIFFER FROM COUNTRY TO COUNTRY, ACCORDING TO THE NATIONAL REGULATIONS. THE EXPECTED VALUE OF SLIPPAGE RESISTANCE OF PRODUCTS BY INDUSTRIE CERAMICHE PIEMME S.P.A. MAY VARY DEPENDING ON THE PRODUCTION BATCH. SPECIFIC DOCUMENTS ARE AVAILABLE UPON REQUEST. PRÜFVERFAHREN, ERFORDERNISSE UND KLASSIFIKATIONEN SIND VERSCHIEDEN VON LAND ZU LAND, GEMÄSS DER NATIONALEN VORSCHRIFTEN. DER ERWARTUNGSWERT DER RUTSCHSICHERHEIT DER PRODUKTE VON INDUSTRIE CERAMICHE PIEMME S.P.A. KANN SICH - JE NACH DER PRODUKTIONSPARTIE - VERÄNDERN. SPEZIFISCHE UNTERLAGEN SIND AUF VERLANGEN ZUR VERFÜGUNG. LES MÉTHODES D'ESSAI, LES RÉQUISITIONS ET LES CLASSIFICATIONS CHANGENT DE PAYS À PAYS, SELON LES RÉGLEMENTATIONS NATIONALES. LA VALEUR ATTENDUE DE RÉSISTANCE AU GLISSEMENT DES PRODUITS DE INDUSTRIE CERAMICHE PIEMME S.P.A. PEUT VARIER EN FONCTION DU LOT DE PRODUCTION. UNE DOCUMENTATION SPÉCIFIQUE EST DISPONIBLE SUR DEMANDE.

ELENCO DELLE SERIE CERTIFICATE E CLASSIFICAZIONI DISPONIBILI A RICHIESTA - LIST OF CERTIFIED SERIES AND CLASSIFICATIONS AVAILABLE UPON REQUEST  
LISTE DER GEPRÜFTEN SERIE UND KLASSIFIZIERUNGEN AUF ANFRAGE ERHÄLTlich - LISTE DES SERIES CERTIFIÉES ET DES CLASSEMENTS DISPONIBLES SUR DEMANDE



CERAMICHE PIEMME  
FLOOR AND ROOF



Reading Guide  
Leseanleitung  
Guide à la lecture

▼ Spessore  
▲ Thickness  
Stärke  
Épaisseur

Variazione nelle sfumature di colore  
Color shade variations  
Variation der Farbnuancen  
Variation des nuances de couleur

Resistenza alla scivolosità  
Skid resistance  
Rutschfestigkeit  
Resistance au glissement

V1 Aspetto uniforme  
Uniform appearance  
Gleichförmiges aussehen  
Aspect uniforme

V2 Variazione leggera  
Slight variation  
Leichte variation  
Variation légère

V3 Variazione moderata  
Moderate variation  
Mäßige variation  
Variation modeste

V4 Variazione casuale  
Random variation  
Zufällige variation  
Variation fortuite

| DIN 51130 | DIN 51097 | DCOF  |
|-----------|-----------|-------|
| R10       | A+B       | >0,42 |

Tutti i formati sono nominali.

All sizes are nominal.

Die Formate sind Nennwerte.

Tous les formats sont nominaux.

Gli spessori riportati in questo catalogo sono nominali e possono variare a seconda dei formati e delle finiture.

The thickness mentioned on this catalogue are nominal and can be different according to the sizes and the finishes.

Die in diesem Katalog angegebenen Fliesenstärke sind nominal und können, je nach Format oder Oberfläche, verschieden sein.

Les épaisseurs reportées sur ce catalogue sont nominales et peuvent varier suivant les formats et les finitions.

I colori e le caratteristiche estetiche dei prodotti sono quanto più possibile vicini a quelli reali, nei limiti consentiti dai processi di stampa.

The colours and appearance features of the products are as close as possible to reality, within the limitation of the printing process.

Die Farben und die ästhetischen Eigenschaften der Produkte entsprechen der Wirklichkeit, innerhalb den von dem Druckverfahren erlaubten Grenzen.

Les couleurs et les caractéristiques esthétiques sont fidèles aux couleurs et caractéristiques réelles dans les limites des procédés d'impression.



#### Una storia tutta italiana

Piemme dal 1962, anno della sua fondazione, è protagonista indiscussa del vero Made in Italy, quello fatto di eccellenza, passione e creatività. Oggi tutti i materiali Piemme sono prodotti con tecnologia d'avanguardia come la decorazione digitale inkjet HD, la cottura in forni ad energia pulita a recupero di calore, la rettifica e levigatura in linea "one roof" e la verifica elettronica dello standard qualitativo.

#### An all-Italian story

Since 1962, the year of its foundation, Piemme has been the undisputed protagonist of real Made in Italy, that which consists of excellence, passion and creativity. Today, all Piemme materials are made using cuttingedge technology such as HD inkjet digital decoration, firing in heat-recycling cleanenergy kilns, "one roof" grinding and polishing line and electronic quality standard control.

#### Eine ganz italienische Geschichte

Seit dem Gründungsjahr 1962 ist Piemme ein unangefochtener Hauptakteur des echten Made in Italy: jenem, das auf Exzellenz, Leidenschaft und Kreativität gründet. Alle Piemme Erzeugnisse werden heute unter Einsatz von Spitzentechnologie produziert, wie zum Beispiel mit der digitalen Inkjet-Dekoration, dem Brennen in Öfen mit grüner Energie und Wärmerückgewinnung, dem Schleifen und Polieren in der Linie „unter einem Dach“ sowie der elektronischen Prüfung des Qualitätsniveaus.

#### Une histoire toute italienne

Depuis 1962, l'année de sa fondation, Piemme est la protagoniste indiscutée du Made in Italy, basé sur l'excellence, la passion et la créativité. Aujourd'hui toutes les phases du cycle de fabrication Piemme sont issues d'une technologie à l'avant-garde comme la décoration numérique inkjet HD, la cuisson dans des fours à énergie propre et à récupération de chaleur, la rectification et le polissage en en ligne "one roof" et la vérification électronique de la qualité.

CERAMICHE PIEMME  
FLOOR AND MORE

INDUSTRIE CERAMICHE PIEMME S.P.A.  
VIA DEL CROCIALE 42/44, 41042 FIORANO (MO) - ITALY  
T. +39 0536.849111 - F. +39 0536.849402  
WWW.CERAMICHEPIEMME.IT - INFO@CERAMICHEPIEMME.IT

